

R o t o r   P a c k

N D R   S e r i e s

I n s t r u c t i o n   M a n u a l

Relating Models :

NDR081-071H-30

NDR151-102H-30

NDR151-103H-30

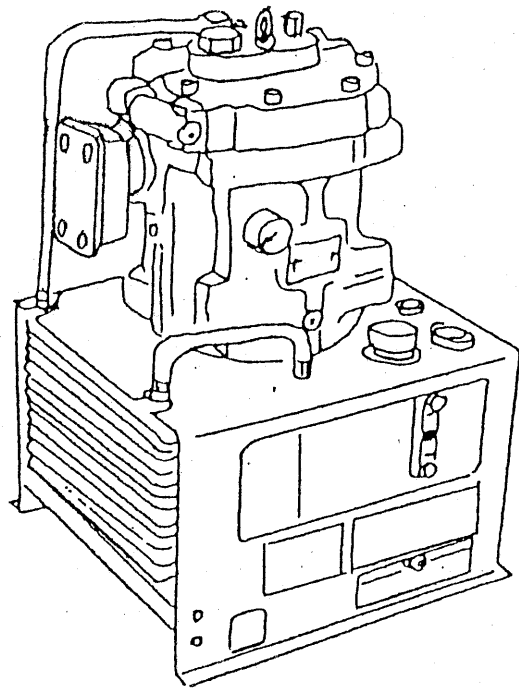

Oil Hydraulic Equipment Department,  
Daikin Industries, Ltd.  
Oil Hydraulic Equipment

COCOM consideration (technical papers)

①. Not needed.	1. Needed.	2. Yet to judge
----------------	------------	-----------------

[Oil hydraulic units]

<< Notes Relating to Safety >>

■ Things required before using an oil hydraulic unit



- You are requested to peruse our documents, including these notes relating to safety, the instruction manual and the specification, for your correct using the unit.
- Surely keep those documents so as to be readily available at any time.

(Note 1) This document is composed of extracts therefrom of the items to which special attentions should be paid to secure safety.

For detailed procedures of handling, refer to the original; the instruction manual and the specification.









(Note 2) You are requested to incorporate the contents of this document in the instruction manuals for your products.

■ On symbols in this document

-  DANGER → imminent danger, feared to cause deaths or grave injuries if not avoided
-  WARNING → potential danger, feared to cause deaths or grave injuries if not avoided
-  CAUTION → potential danger, feared to cause light or medium injuries or damages or breakages of properties





## ■ Precautions for safety

### (1) Generals







-  DANGER ① Ask works of transportation, installation, piping, wiring, operation, maneuvering, maintenance and inspection to persons with expertise.
-  DANGER ② Surely observe the following in working on the units:  
\* Surely set power supply off, putting the unit into off condition.  
\* Assure "zero pressure" in the hydraulic piping. If not, extract pressure in accordance with the procedures described in the instruction manual or appended materials.
-  DANGER ③ Never use the unit in an explosive environment. Or, a fire or a human accident can be caused.
-  CAUTION ④ Do not use the unit out of the conditions stated in the catalog or the delivery specification. Or, a big accident of a damage of the main equipment, an injury, a fire or an electric shock can occur.
-  CAUTION ⑤ Any modification of our product by the user is out of our guarantee. The Company is perfectly free of any responsibility for any result of such a modification.
-  CAUTION ⑥ Surely execute the routine inspection (which is stated in the instruction manual or appended materials).
-  CAUTION ⑦ Surely use the hydraulic oil recommended by the Company.
-  CAUTION ⑧ Do not use the unit in an extraordinarily hot or humid atmosphere.
-  CAUTION ⑨ Do not be present on, hit or apply any external force on the hydraulic unit. Or, an injury or a breakage can occur.

### (2) Transportation





Falling or turning down of a hydraulic unit is very dangerous since it is heavy. Observe the following in transporting it. (Or, an injury or a breakage can occur by falling or turning down of the unit.)

-  DANGER ① Assure the unit weight (stated in the assembly drawing), and hang only a unit of a weight within rating of the hanger.
-  DANGER ② Surely hook the load securely at the specified points (stated in the assembly drawing).
-  WARNING ③ Never be near a load being transported by a hanger.  
Or, an injury or a breakage can occur by falling or turning down of the load.
-  CAUTION ④ Fix the load securely so that it does not move by vibration or an external force during transportation.

(3) Installation, adjustment and trial operation

-  CAUTION ① Assure the unit's fixing position on the assembly drawing, and fix it with bolts or anchor bolts securely.
-  DANGER ② Ground the earthing terminal securely. Or, an electric shock is feared.
-  CAUTION ③ Do not put an obstacle interfering ventilation around a motor or a fan cooler. Or, a breakage or a burning injury can be feared due to an extraordinary heating as a result of interfered cooling.
-  DANGER ④ Covers are provided for safety on revolution portions. Never insert fingers into a gap beneath the cover. Or, an injury is feared.
-  CAUTION ⑤ For star-delta starting of an electric motor, select one with an electromagnetic switch(3-contactor system) on its primary. Or, a fire is feared.
-  CAUTION ⑥ Fill a suitable quantity of hydraulic oil in the oil tank and the hydraulic pump case(in the case of a piston pump).(For the suitable quantity, refer to the specification or the instruction manual.)
-  CAUTION ⑦ Observe the following in a trial operation of an oil hydraulic unit. Or, an injury or a breakage is feared.
- \* The main equipment should be in a safe condition(not performing or no trouble occurring if performing).
  - \* Assure direction of revolution by a few operations of inching. (assuring revolution performance and rise of the pressure gauge indication)
  - \* Extract air surely.

(4) Wiring and piping

-  CAUTION ① Make wiring in accordance with the Technical Standards of Electrical Equipment or the Regulation on Indoor Installations. Or, a burning damage or a fire can occur.
-  CAUTION ② No protector is appended to an electric motor used in our products. The user is requested to provide it since the Technical Standards of Electrical Equipment specifies installation of an overload protector. Installation of any of other protectors (such as a ground fault circuit interrupter) is also recommendable.
-  DANGER ③ Make connections with the power supply cable in accordance with the wiring diagram in the specification or the instruction manual. Or, an electric shock or a fire is feared.
-  DANGER ④ Do not give too sharp a bending, too high a tension or a squeezing pressure to the power supply cable or the lead wires for units such as a motor. Or, an electric shock is feared.

(5) Operation



CAUTION

① The motor casing, the hydraulic pump body and the coil portion of solenoid valve will be very hot during operation. Do not touch any of them via a hand or another part of body. Or, a burning injury is feared.



CAUTION

② Stop operation immediately when an abnormality has occurred. Or, an accident such as a breakage, an electric shock, a fire or an injury is feared.



DANGER

③ Do not take off a terminal box cover from a motor or an electrical part being operated. Or, an electric shock is feared.



CAUTION

④ Do not operate a motor continuously with its capacity overridden. Or, its coil can be burnt or a fire can occur due to overcurrent.



DANGER

⑤ Surely set the switch off in a halt.

(6) Maintenance and inspection



CAUTION

① Do not touch the motor, frame or the hydraulic pump body with a bare hand, since they are very hot in operation. Or, a burning injury is feared.



DANGER

② Ask a repair, a disassembling or a modification of the unit surely to experts.



CAUTION

③ Inspect electrical parts (such as switches for the motor, pressure, temperature or oil level) periodically.

For procedures, refer to the instruction manual or appended materials.

## Contents

	Page
1. Forewords -----	7
2. Model symble construction -----	7
3. Product specifications -----	8
4. Componentd' names -----	9
5. Hydraulic circuit -----	10
6. Cautions for transportation, movement and installation -----	11
7. Preparations before operation -----	13
Filling hydraulic oil -----	13
Wiring the rotor pump -----	14
Wiring the oil cooler -----	16
Piping -----	19
8. Trial operation -----	20
9. Setting pressure and flow rate -----	21
10. Maintenance and management -----	23
Maintenance procedure of the oil tank and oil -----	25
Maintenance procedure of the oil cooler -----	27
Maintenance procedure of the oil inlet port(also working as the air breather)-	29
Maintenance procedure of the suction strainer -----	30
11. Construction cross-section and parts list -----	31
12. Tank oil temperature rise -----	33
13. Outside drawing -----	34
NDR081-071H-30 -----	34
NDR151-102H-30 -----	35
NDR151-103H-30 -----	35

## 1. Forewords

The Rotor Pack NDR Series product is Daikin's hydraulic unit for working machines and general industrial machines. It mounts the rotor pump designed and manufactured in an utmost pursuit to low noise and small size, and develops the rotor pump's features to the maximum. Equipped with the oil cooler as standard, it also minimizes size of oil tank as well as oil temperature rise.

To make full use of the Rotor Pack NDR Series product's performance and ability for a long span of time, please peruse this instruction manual for suitable handling and maintenance.

## 2. Model symbole construction

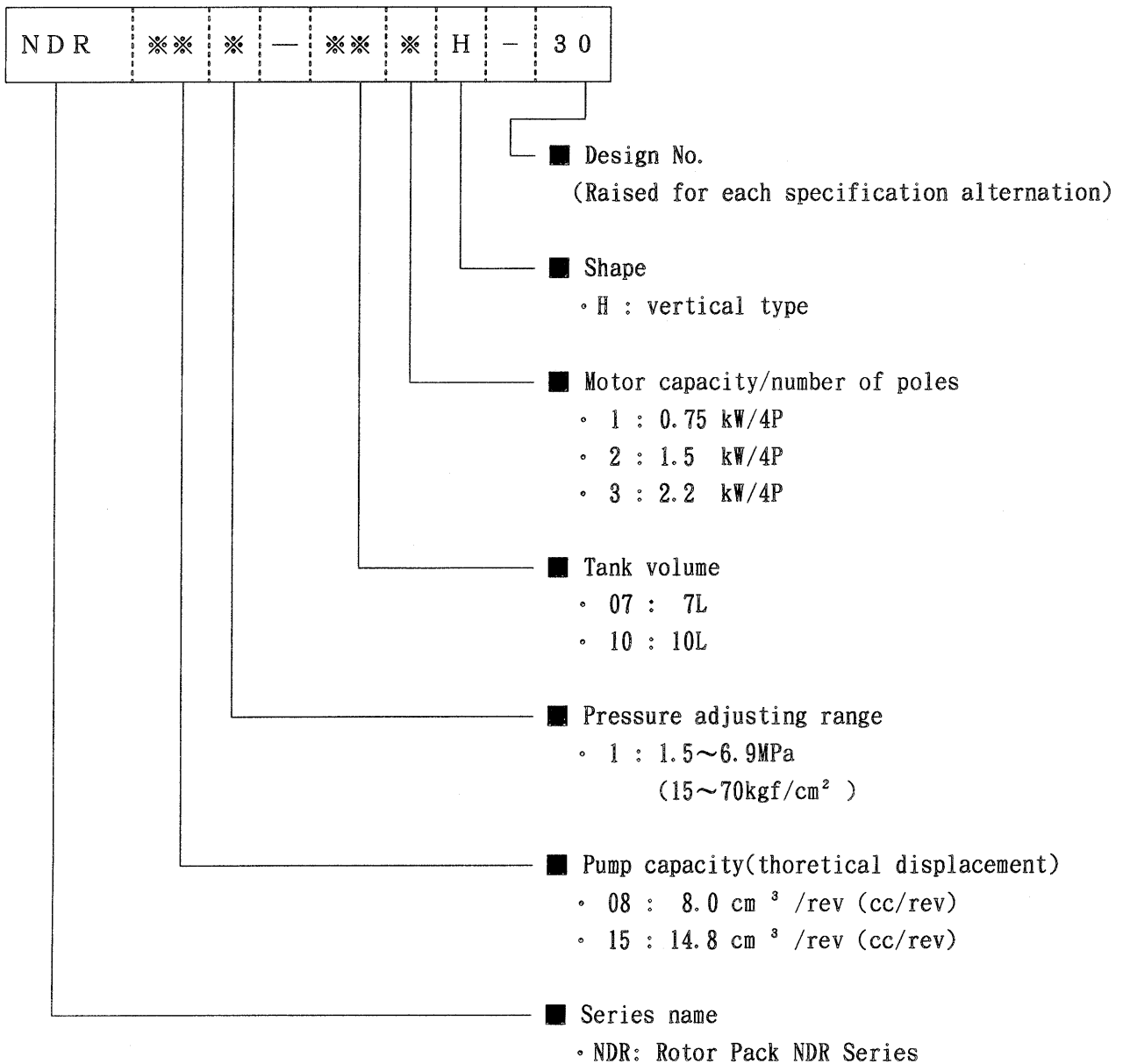

### 3. Product specifications

#### ■ Main specifications

Model		NDR081-071H	NDR151-102H	NDR151-103H
Oil tank volume		7L	10L	
Pump motor capacity		0.75KW, 4P	1.5 kW, 4P	2.2KW, 4P
Maximum working pressure (kg/ cm <sup>2</sup> )		Note 1) 6.9 (70)		6.9 (70)
Pressure adjusting range (kg/ cm <sup>2</sup> )		1.5 ~6.9 (15 ~70)		
Discharge rate L/min	50 Hz	4.0 ~11.7	10.0 ~20.8	
	60 Hz	4.8~14.0	12.0~25.0	
Mass kg		48	75	
Oil cooler motor capacity		16/17.6 W (50/60 Hz)		
Power supply	pump motor	3-φ AC 200/200/220 V, 50/60/60 Hz		
	oil cooler motor	1-φ AC 200/200/220 V, 50/60/60 Hz		
Coating color		White (Munsell N7.5 or equivalent)		

Note 1) NDR081-71H and NDR151-102H are shipped with a pressure set at 3.4 MPa (35 kgf/cm<sup>2</sup>).

Note 2) This range is adjustable with the flow rate adjust screw. It is set at the maximum flow rate (under the no-load condition) in shipping.

#### ■ Working conditions

Note 1) Oil	Mineral type special hydraulic oil/wear-resistant hydraulic oil (For the company's recommendation, refer to Daikin's General Catalog of Hydraulic Units.) <ul style="list-style-type: none"> <li>• Viscosity grade ... ISO VG 32 ~68</li> <li>• Viscosity range ... 15~40mm/s (cSt)</li> <li>• Water content ... 0.1 vol% or less</li> <li>• Contamination ... NAS class 10 or less</li> </ul>
Note 2) Tank oil temperature	0 ~60°C (recommendation : 15 ~50°C)
Ambient temperature	0 ~35°C
Humidity	20 ~ 85% RH
Place of installation	Indoor(stationary type), to be fixed with bolts
Protection of pump motor	To be surely protected with a no-fuse breaker and an earth leakage breaker

Note1) Do not use any hydraulic fluid other than mineral type (hydrous or synthetic) hydraulic oil (like water and glycol).

Note2) For tank oil temperature rise depending on operation condition, see page 33.



4. Components' names

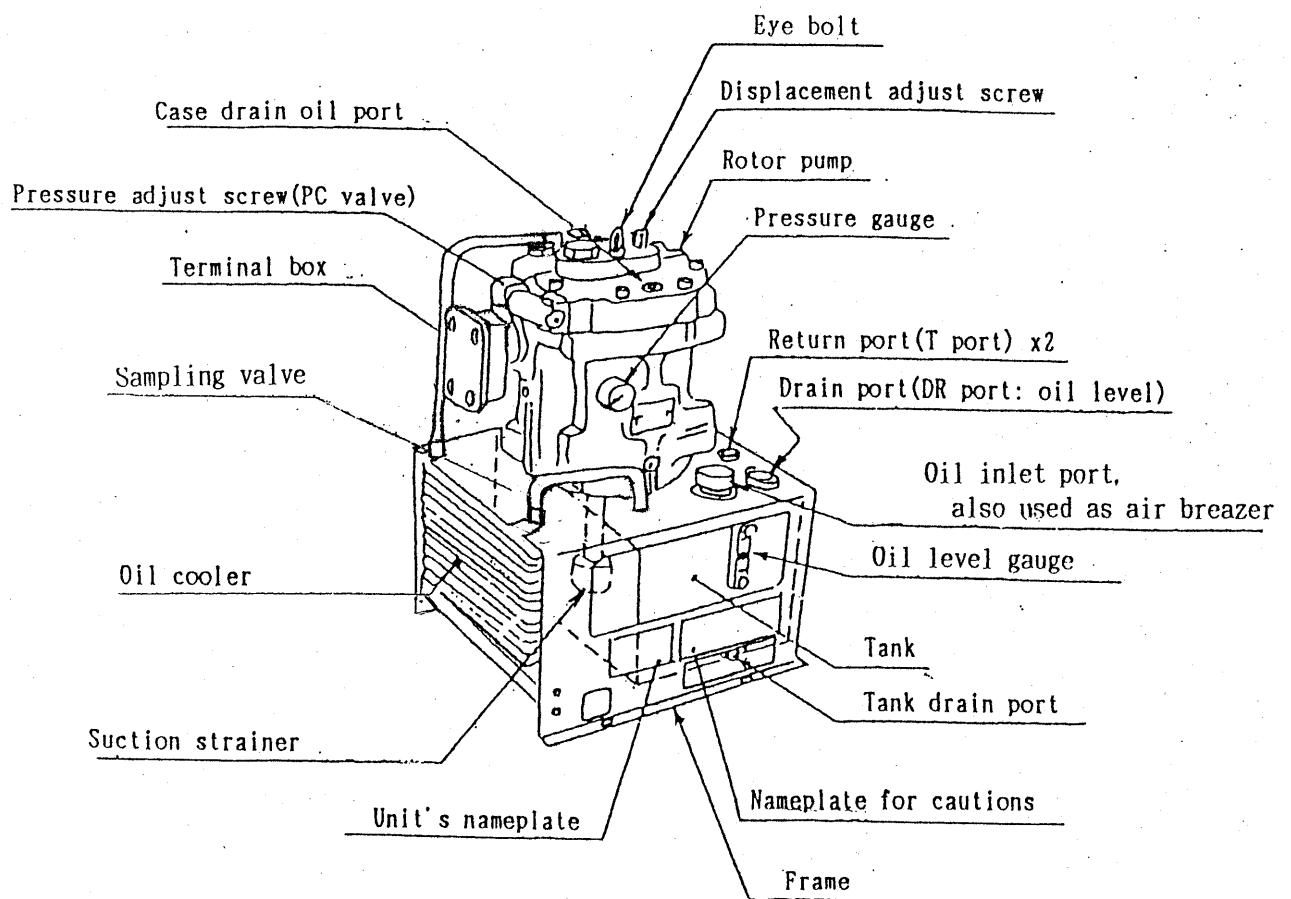
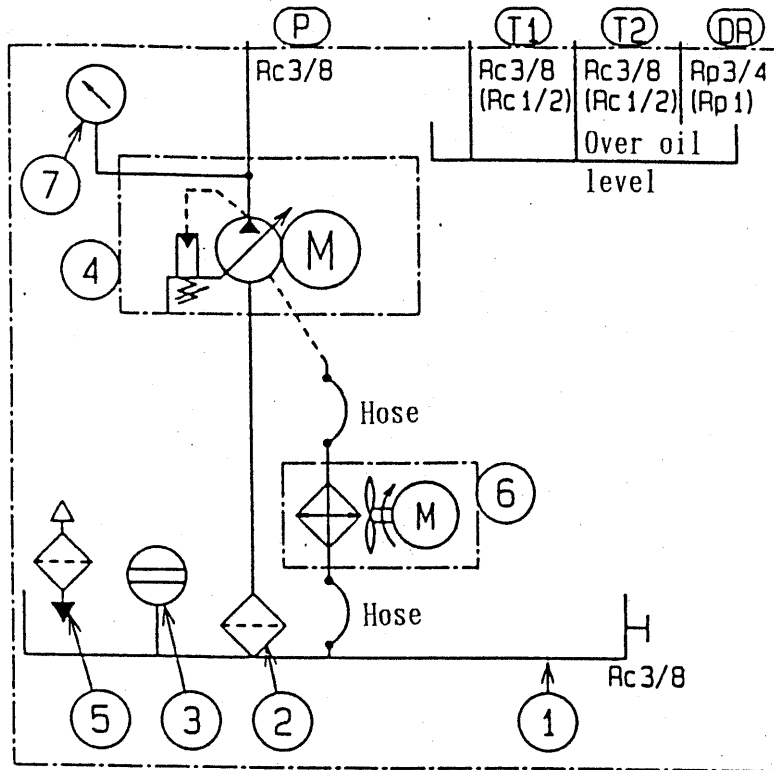

Fig.1

5. Hydraulic circuit

■ Hydraulic circuit



Symbols and numbers inside ( ) : for NDR151  
 Symbols and numbers outside ( ) : for NDR081

■ Components

Part No.	Name	Type		
		NDR081-071H	NDR151-102H	NDR151-103H
1	Oil tank	7L	10L	
2	Suction strainer	DHA-04-150	DHA-06-150	
3	Oil level gauge	KLA-80SA		
4	Rotor pump	RP08A1-07-30-001	RP15A1-15-30-001	RP15A1-22-30-001
		Motor capacity	0.75KW 4P	1.5KW 4P
5	Oil inlet port, also used as air breather	MSA-V22		
6	Oil cooler	DCR10BP-10		
7	Pressure gauge	ADGT-PT-1/4X $\phi$ 39 X 100K X 10MPa		

6. Conditions for transportation, movement and installation

Transportation and movement

Surely use the hanging bolt for transportation and movement.

Type	NDR081-071H	NDR151-102H/103H
Mass	48 kg	75 kg

<Cautions>

- Hanging via the pump drain pipe or the like may cause breakage.
- Do not move the unit with the tank containing oil.  
(Otherwise; oil leakage, aeration or malfunction of the air breather may be caused. )

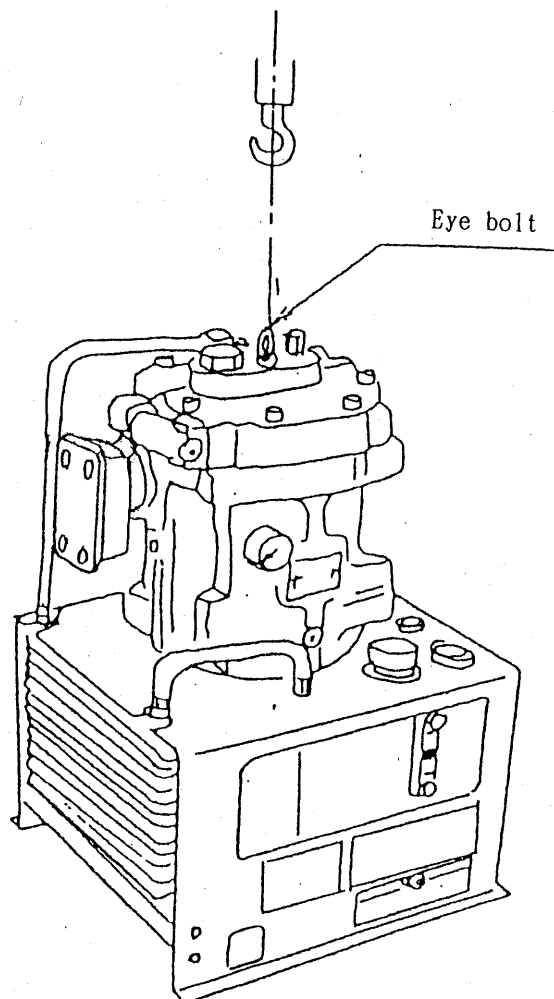

Fig. 2

Cautions for installation

■ Secure space for suction and discharge of air.

Do not put any obstacle to the oil cooler's sucking and discharging air within 10 cm from the sucking or discharging face of the oil cooler. Install the unit at a place of good ventilation to avoid heat accumulation.

< Cautions >

- Installation at a place with an obstacle or where heat accumulates will disturb heat exchange of the oil cooler so to raise oil temperature abnormally, which will, in turn, cause disorders of the hydraulic unit such as the pump or short life of oil, which will also cause disorders of the unit.  
Abnormal oil temperature rise may also scalds.

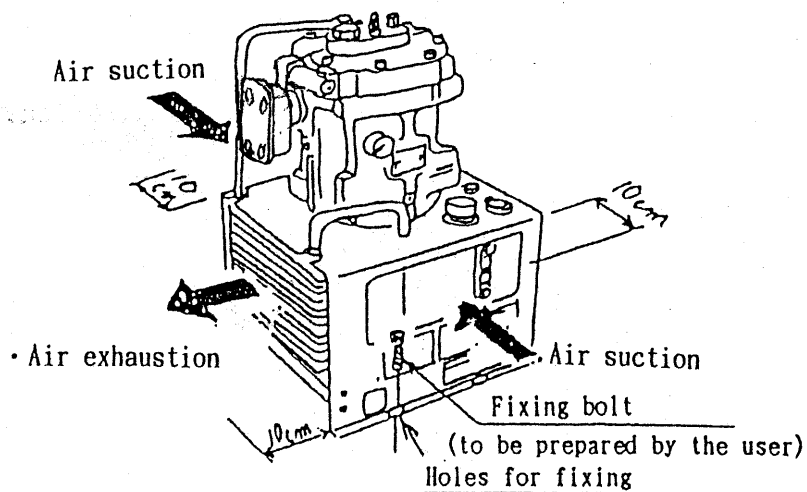

Fig. 3

■ Fix the unit on a horizontal base or floor.

< Cautions >

- Fixing the unit on a slope may cause oil leakage or aeration.

7. Preparations before operation

Filling hydraulic oil

Put oil in the tank and the rotor pump. Use oil complying to the specification given on p. 7.

● Case drain oil port

Fill the rotor pump case with hydraulic oil.

[Case drain volume]

Type	NDR081	NDR151
Mass	1.1L	2.3L

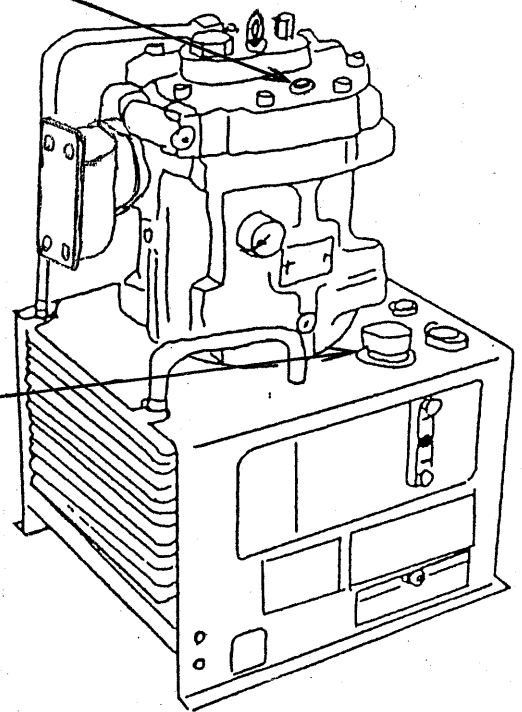

● Oil inlet port, also used as the air breazer

Take the cap off by turning it to left, and pour hydraulic oil. The oil quantity should be such that the oil level gauge float be between the yellow and the red line.

[Oil level range]

Type	NDR081	NDR151
Yellow line (upper limit)	7.0L	10.0L
Red line (lower limit)	5.0L	7.4L

< Cautions >

- For a long time operating the unit with the tank and the pump case containing no oil may damage of the rotor pump due to locking by seizure.

Wiring the rotor pump

- Surely provide a no-fuse breaker for the main power supply to protect the electric circuit against overcurrent such as shortcircuit and the motor against overload. And, install an earth leakage breaker also.

[Rotor pump's current rating (100% load)]

Type		NDR081-071H	NDR151-102H	NDR151-103H
AC200V	50Hz	3.8A	6.8A	9.6A
	60Hz	3.4A	6.0A	8.8A
AC220V	60Hz	3.4A	5.8A	8.4A

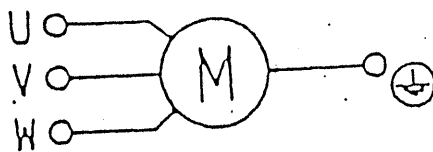
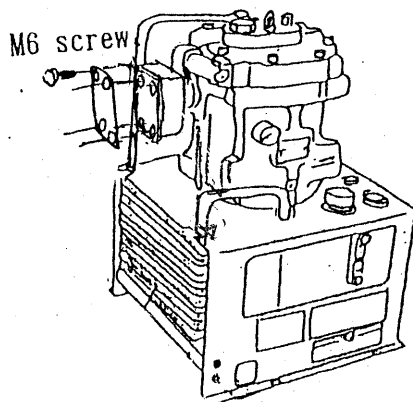

- For selection of the no-fuse breaker capacity, refer to the Table of Rotor Pump's Current Rating given above since current value depends on operation conditions.
- Similarly, use wire of the correct specification and nominal cross sectional area based on the current value.

■ Wiring procedures

- ① Loosen the screws(M6 screw) for the terminal box and take apart the cover.
- ② Insert wire into the wire port of the terminal box. Use wire conduit or something equivalent suitable for the port (  $\phi 23$ ).
- ③ Connect wire to the terminal box (M5 screw). For connection, use round compression terminals of a suitable size and connect tightly and securedly so as to prevent the connection from getting loose, in order to eliminate danger of phase-to phase shortcircuit and leakage to the unit body. Make wiring so that no tension is born by wire.
- ④ After completig connection, fix the terminal box cover as it was before.

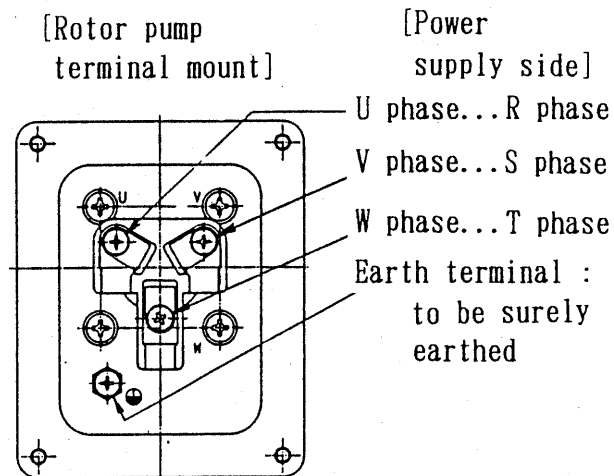

< Cautions >

- Take sufficient care in wiring because wiring in procedures not based on the above description may cause not only malfunction and troubles of the rotor pump but accidents occurring therefrom

## Wiring the oil cooler

### ① Electrical specifications for the oil cooler fan motor

Electrical rating list			
Motor	with shading coils for impedance protection		
Voltage (V)	200	200	220
Frequency (Hz)	50	60	60
Operating current(A)	0.12	0.11	0.10
Input power (W)	16	15	17.6
Current as locked(A)	0.17	0.15	0.18
Starting current (A)	0.17	0.15	0.18
Lead wire	Heat resistant flat double cored vinyl code(to JIS C 3306) length : 1000 mm, outside dimensions : 5.4 X 2.7 mm, core size : 0.75 mm <sup>2</sup> coating color : black		

### ② Providing the protector

The oil cooler fan motor is provided with the impedance protection making use of coil resistance to prevent burning of the coil when the fan is locked by external force. But, provide an additional protector such as a no-fuse breaker of about 0.5A against overcurrent caused by troubles including shortcircuit.

### ③ Method of connection

This unit adopts the lead wire direct connection system (with flat double cored vinyl code). Connect wire tightly by fixing terminals on wire ends or soldering.

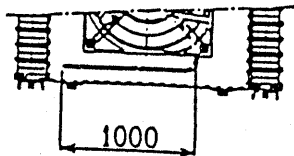

Details of the oil cooler wiring

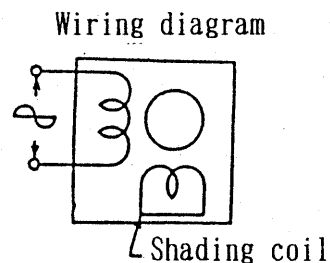



Cautions for wiring the oil cooler

An overcurrent breaker should be installed for each of the pump motor and the oil cooler fan motor in wiring the Pack product. Be noted that the following regulations must be observed to pass wires for the two systems in one flexible tube:

● Yes-or-no for wiring

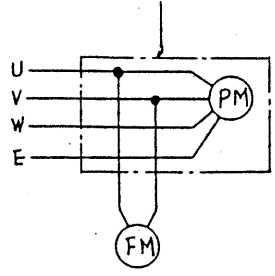
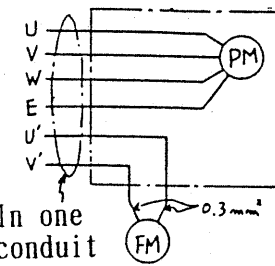
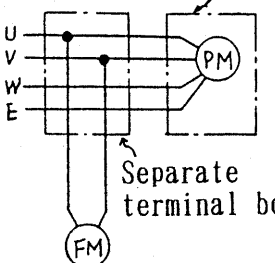
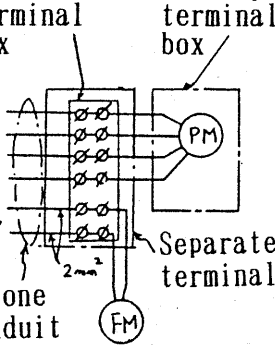
No.	Object of judgment	Relating regulation	Yes-or-no	Remark
1	Rotor pump terminal box 	R11 150-10 (TS 185)	No	The rotor pump overcurrent breaker cannot protect the fan motor wire because of a large difference between the rotor pump's rated current and the fan motor's operation current.
2	Rotor pump terminal box 	R11 400-5 (TS 179)	No	The oil cooler wire size, $0.75\text{mm}^2$ , does not meet the regulation specifying not less than $2\text{mm}^2$ .
3	Rotor pump terminal box 	R11 150-10 (TS 185)	No	same as No. 1
4	Terminal box Rotor pump terminal box 	R11 400-5 (TS 179) R11 410-5	Yes	Yes because this wiring complies to R11 400-5 and 400-5, provided that a conduit size meeting R11 410-5 is adopted

Note ) No motor burning damage of the fan motor occurs when the fan is locked by external force since the motor is protected with an impedance protector. But, an over-current breaker is needed for protection in case of line-to-line shortcircuiting.

- Relating standard and regulation :
  - Technical Standards of Electrical Equipment (a ministry ordinance stipulating technical standards relating to electrical equipment) → TS”  
Established on June 15, 1965  
setting technical standards relating to electrical equipment  
based on Par.1. Art.48 and Par.1, Art.67 of Electrical Enterprise Law  
(Law No.170, 1964)
  - Regulation on indoor installations (part of actual installations for TS,  
regulating actual practices and installations) → R11”

## Piping

- The Rotor Pack product is provided with two return ports, one drain port and one discharge port. Make piping for those ports according to necessity. All ports are blocked with taper plugs (vinyl caps) in shipping. In piping, lap sealing tape around the end and tighten the pipe with the torque given in the table below :

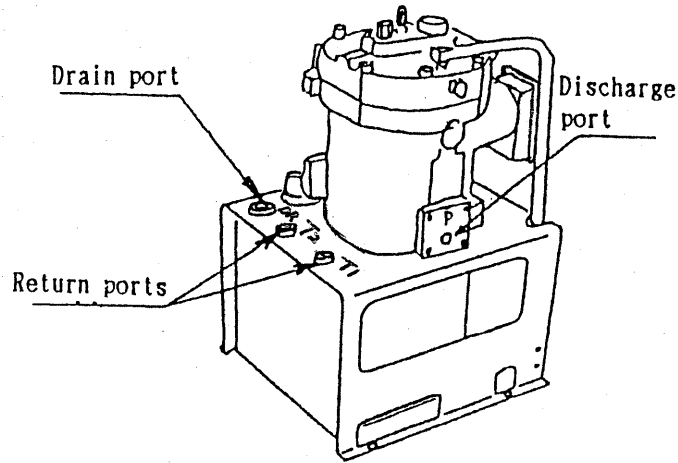

Fig. 7

Type	NDR081	NDR151
Discharge port(x1) Note1	Rc 3/8	Rc 3/8
Return ports(X2) (under oil level)	Rc 3/8	Rc 1/2
Drain port(X1) (Over oil level)	Note2 R <sub>p</sub> 3/4	Note2 R <sub>p</sub> 1

Size	Tightening torque (N-cm) {kgf- cm }
Rc3/8	4,214 ~ 4,655 ( 430~ 475)
Rc1/2	6,272 ~ 6,860 ( 640~ 700)
R <sub>p</sub> 3/4 Note2	10,780 ~11,760 (1,100~ 1,200)
R <sub>p</sub> 1 Note2	15,190 ~16,660 (1,550~ 1,700)

Note 1 : A manifold can be directly attached to the port since it can be used as a flange.

Note 2 : R screws are set in R<sub>p</sub> screws. Tightening at the specified torque prevents oil leakage.

## 8. Trial operation

Fill the pump case in the tank with oil of the specified volume. Start trial operation after finishing wiring and piping.

### Inching operation

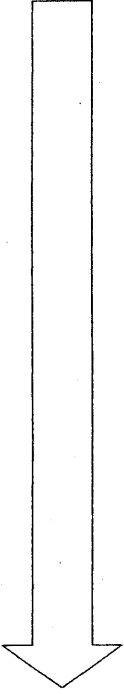

- Repeat two or three inching operations. Then, set the switch on.
- Assure pressure rise. If pressure does not rise for more than five minutes, suspected is a wrong phase sequence in the wiring. interchange two wires of the three and retry to raise pressure.

#### <Cautions>

- Wrong phase connection  
Long time operation with a wrong phase connection (reverse rotation) may cause damages inside the pump.

- Assure the oil cooler fan rotation.

#### <Cautions>

- Oil cooler fan stop  
Operation with the fan stopped may cause an abnormal oil temperature rise as well as short life of oil due to disorder of the hydraulic unit including the pump. An abnormal temperature rise may also cause scalds if touched by hands.

### Flushing operation

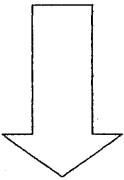

- Execute flashing operation for two hours with a circuit pressure of 1 to 1.5 MPa { 10 to 15 kgf/cm<sup>2</sup> } after finishing inching operation. For flushing operation, connect all pipings except the actuator in a loop and attach a filter of about 10 $\mu$ m nominal in the return pipe near the oil tank.

### Replacement of oil

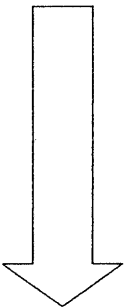

- Drain all oil from the drain port of the tank after finishing operation, and fill the tank with new hydraulic oil of the specified quantity through the oil port (also working as the air breather).  
(New oil should be oil within NAS class 10 and contain water not more than 0.1 %vol.)
- Check oil level change due to volume difference of the hydraulic cylinders.

### Removal of air

- Carefully remove air out of the hydraulic circuit.

#### <Cautions>

- Imperfect removal of air may cause the following :
  - Abnormal performance of actuators such as the air cylinder
  - Noise issued from the rotor pump

## 9. Setting pressure and flow rate

Pressure and flow rate can be adjusted if necessary.

### Adjusting pressure

■ Discharge pressure depends on load conditions. The PC setting pressure, the upper limit of the discharge pressure, can be changed through the pressure adjust screw.

- Turn to right (CW) : Raise the pressure
- Turn to left (CCW) : Drop the pressure

- Adjusting pressure range : 1.5 ~ 6.9 MPa  
(15 ~ 70 kgf/cm<sup>2</sup> )

- Pressure change (approximate per one turn) : NDR081: 2.0 MPa (20 kgf/cm<sup>2</sup> )  
NDR151: 2.0 MPa (20 kgf/cm<sup>2</sup> )

### < Cautions >

- Too much loosening of the adjust screw (left turn : CCW )  
Be careful so that the Pc pressure setting be not lower than 15 kgf/cm<sup>2</sup> in adjustment after shipping since too much loosening of the screw may cause dangers of oil leakage from the thread portion and coming out of the pressure adjust screw and valve inner parts together with oil.

### Adjusting discharge rate

■ Discharge rate can be set through the discharge adjust screw.

- \* Turn to right (CW) : Decrease the discharge rate
- \* Turn to left (CCW) : Increase the discharge rate

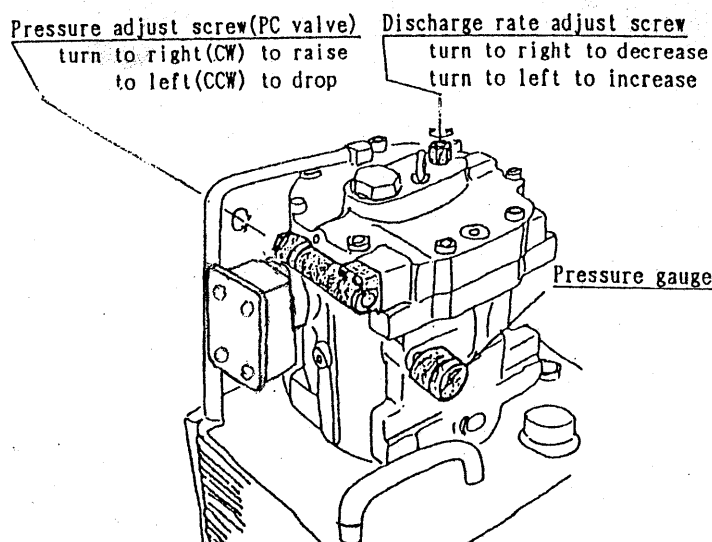
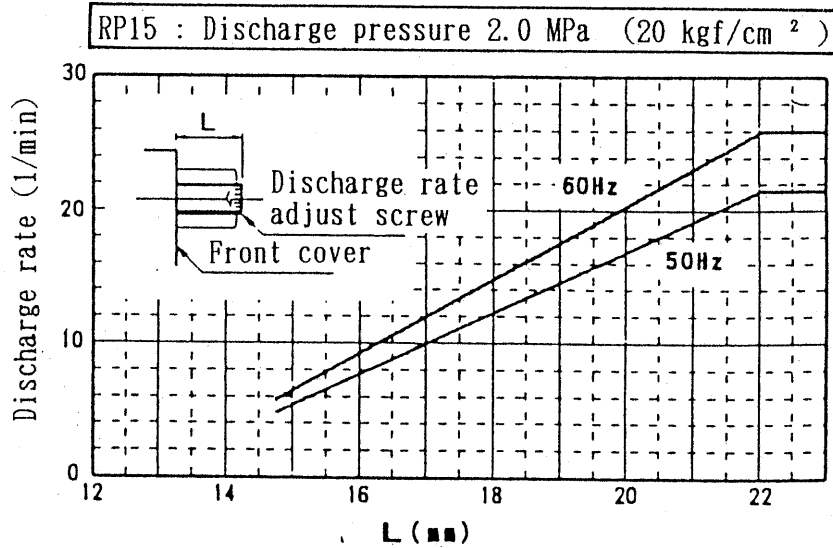
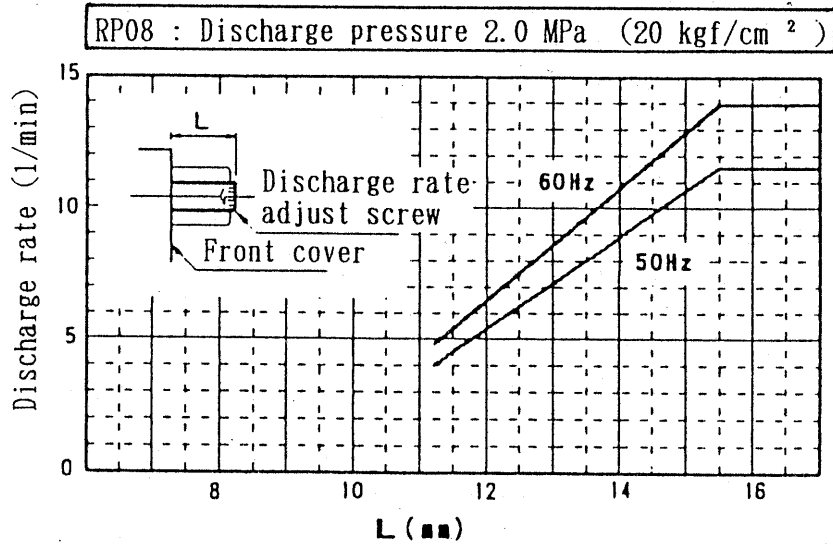

Fig. 8

Setting values for shipping

Type	NDR081-071H	NDR151-102H	NDR151-103H
Pressure	3.4 MPa (35 kgf/cm <sup>2</sup> )		6.9 MPa (70 kgf/cm <sup>2</sup> )
Note 1)	11.7 L/min (50Hz)	20.8 L/min (50Hz)	
Discharge rate	14.0 L/min (60Hz)	25.0 L/min (60Hz)	

Note 1) Those discharge rate setting values are for 60 Hz at the pressure of 1.0 MPa (10 kgf/cm<sup>2</sup>). The values for 50 Hz are theoretical conversions.



10. Maintenance and management

Execute maintenance and management of the unit periodically on the items listed in the tables below to ensure full development of its performance and ability for a long span of time.

Inspection

Objective part/time	Inspection frequency	Method of inspection
<p>Oil tank</p> <ul style="list-style-type: none"> <li>• Checking oil quantity</li> <li>• Checking oil temperatur</li> <li>• Checking oil color</li> </ul>	<p>Every day</p> <p>Every day</p> <p>Once a half year</p>	<p>Assure that the oil level float is between the red and the yellow lines. Check opacqueness and mixing of bubbles of oil at the same time.</p> <p>Normally not higher than 60 °C</p> <p>Oil degradation can be assured also through its color. When it has got fairly brownish, replace it. Standard for this judgment is L4 level (bright yellow) by ASTM.</p>
<p>Oil cooler</p> <ul style="list-style-type: none"> <li>• Fan motor</li> <li>• Core clogging</li> </ul>	<p>Every day</p> <p>Once a half year</p>	<p>The fan motor is to run. If it stops, oil becomes hot because the oil cooler capability is largely reduced. This may cause scalds or accelerate oil degradation.</p> <p>Visual inspection</p>
<p>Pressure gauge</p> <ul style="list-style-type: none"> <li>• Checking performance</li> <li>• Checking pressure indication</li> </ul> <p>Noise</p>	<p>Every day</p> <p>Every day</p> <p>Every day</p>	<p>The pointer is to show no shaking and be alive.</p> <p>Assure the zero pressure point with the pump stopping. Assure D. H.</p> <p>No uncontinuous noise nor abnormal noise.</p>
<p>Electrical wiring</p> <p>Rubber hose</p>	<p>Once a half year</p> <p>Once a year</p>	<ul style="list-style-type: none"> <li>• No crack nor break of the wire coating.</li> <li>• No loosening of the compression terminal tightening screws.</li> <li>• Insulation conditions to be perfect.</li> </ul> <p>No crack, no break nor fissure.</p>

Cleaning and replacement work

Objective part/time	Inspection frequency	Method of inspection
<p>Oil tank</p> <ul style="list-style-type: none"> <li>• Replacing oil</li> </ul>	<p>Once a year</p>	<p>Replace oil in the procedure in accordance with the maintenance procedures described on p.25. A long term operation without replacing oil may largely reduce performance and life of the hydraulic unit.</p>
<p>Oil cooler</p> <ul style="list-style-type: none"> <li>• Core cleaning</li> </ul>	<p>Once a year</p>	<p>Disassemble the cooler and clean the parts in the procedures in accordance with the maintenance procedures described on p.27.</p>
<p>Oil inlet port, working also as the air breather</p>	<p>Once a year</p>	<p>Purge the element (of sponge) with air in the procedures in accordance with the maintenance procedures described on p.29.</p>
<p>Suction strainer</p>	<p>Once a year</p>	<p>Disassemble and clean or replace this part in the procedures in accordance with the maintenance procedures described on p.30.</p>



## Maintenance procedures of the oil tank and oil

### Procedures of cleaning the oil tank

① Taking the tank cover off

Remove the eight truss head small screws with a cross hole, M5 x 10L, and take and take the tank cover off.

② Cleaning the tank

Wipe dirt and accumulations carefully off with waste cloth from the inside and the outside of the tank.

③ Re-attaching the tank cover

Re-attach the tank cover with the truss head small screws with a cross hole removed in ①.

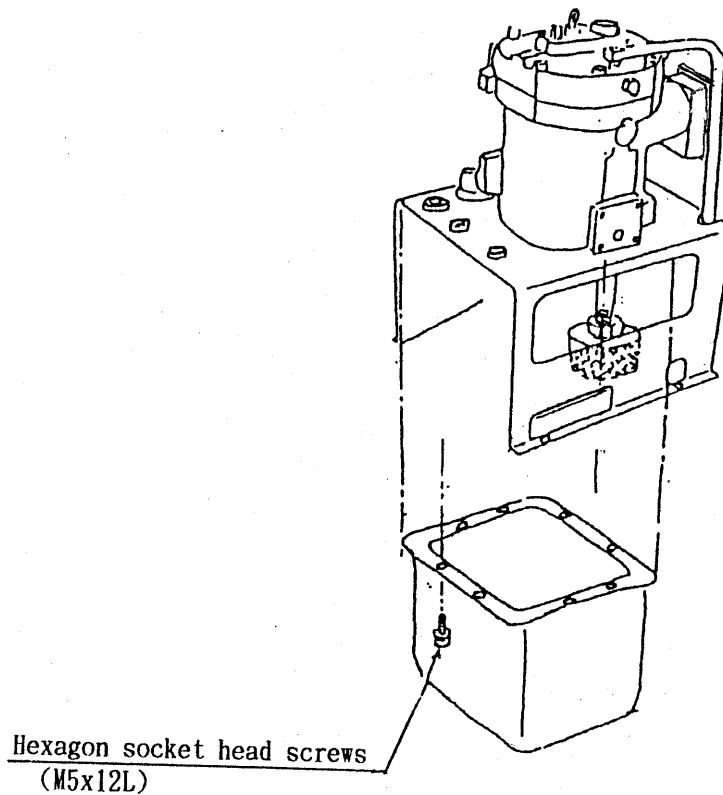

Fig. 11

Procedures of extracting and re-pouring oil

① Extracting oil

Take the plug off the tank drain port. Oil comes out from the drain port. Receive it with a container. After draining completely, replug the port. Lap seal tape on the plug before replugging.

② Re-pouring oil

Take the cap off the oil inlet port, working also the air breather, by turning it to left. The cap is attached with a line of chain so as not to get lost. Re-pour oil which complies with the specification described on p.7. Oil quantity should be such that the oil level gauge float be between the red and the yellow lines.

[Oil level range]

Type	NDR081	NDR151
Yellow line (standard)	7.0 L	10.0 L
Red line (lower limit)	5.0 L	7.4 L

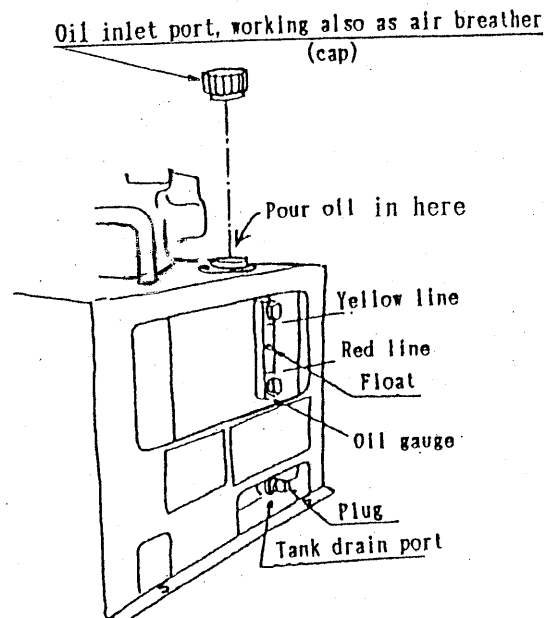

Fig. 12

## Maintenance procedures of the oil cooler

■ Before you start any maintenance (on page 23), stop operation and break the main power supply.

■ Avoid applying strong force to the fan motor lead wire during work

■ Be careful of oil coming out from pipe or the oil cooler during disassembling use oil pan

### ① Taking the oil cooler apart

- Take the two pump drain pipings apart
- Take apart the mounting bracket affixing bolts. M5x16L  
(Hexagon socket head cap screws)

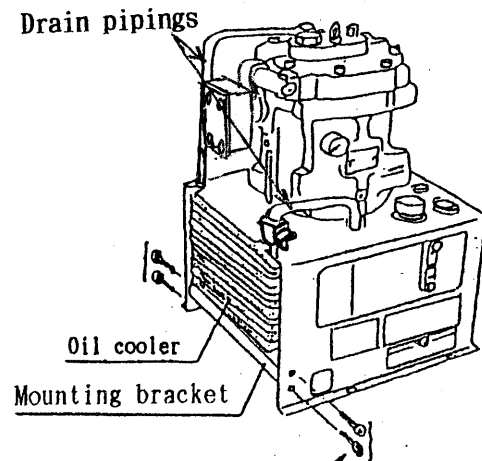
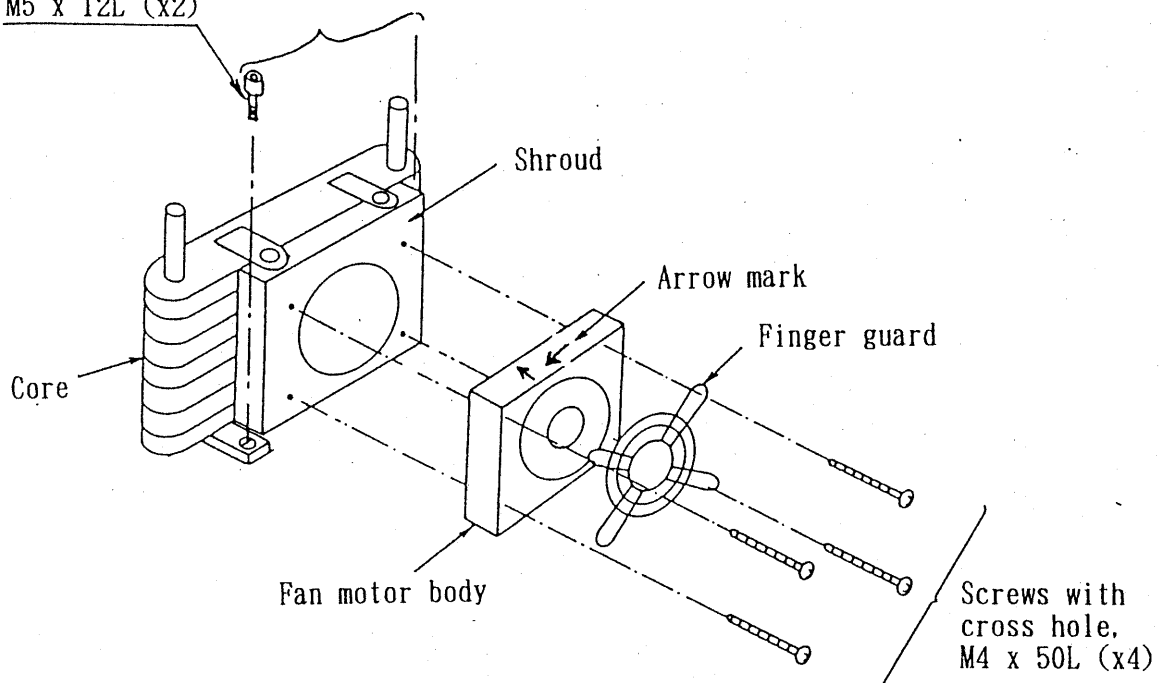

Fig. 13 Hexagon socket head screw (M5x16L)

### ② Disassembling the oil cooler

- Take off the mounting bracket by removing the hexagon socket head screws (M5x12L)
- Take off the core and the shroud by removing the cross-recessed head screws (M5x12L)
- Take off the fan motor and the finger guard from the shroud by removing the cross-recessed head machine screws (M4x50L)

Bolts with hex hole,  
M5 x 12L (x2)



③ Cleaning the core

■ Wear protective glasses and gloves for protection against dangers.

- Take care of the core fins, which are sharp.
- Take care against foreign particles' getting into eyes in blowing air for cleaning.

Blow the core with stream or air to fly accumulated dust and oil off the fins.  
In this way, clean the fins and others.

Take care so that the accumulations are not blown into inside of the core.

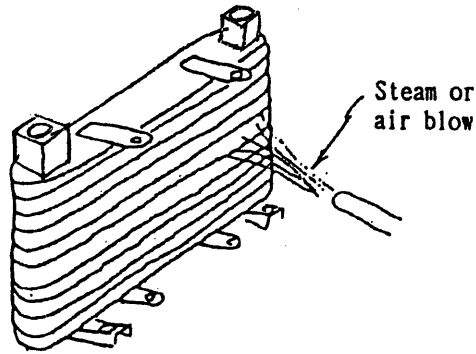

Fig. 15

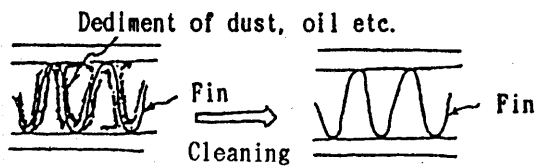

Fig. 16

④ Cleaning the fan motor

Wipe the blades and the casing clean including the peripheries of blades and the space to casing.

< Cautions >

Steam or air-blowing is absolutely prohibited in this case, which may blow foreign particles into inside of the motor.

- After finishing cleaning, reassemble the oil cooler as it was by reversing the instruction given on page 27
- After finishing reassembly, make sure that the unit operates normally in the procedures of trial operation described on p. 20.  
(Particularly, be careful about direction of air suction and discharge.)

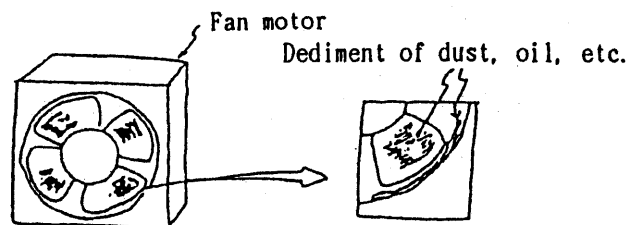

Fig. 17

Maintenance procedures of the oil port(also working as the air breather)

① Taking the cap apart

Take the cap apart. It can easily be taken apart by turning it left by hand. There is no chance to loose it because it is connected to a line of chain.

② Cleaning

Air-blow the filter to blow accumulations off. Wear protective glasses to prevent the blown accumulations from getting into eyes.

Also remove dust from the inner cylinder of the strainer(30 mesh metallic net) if any.

③ Reattaching the cap

Reattach the cap by turning it until it stops.

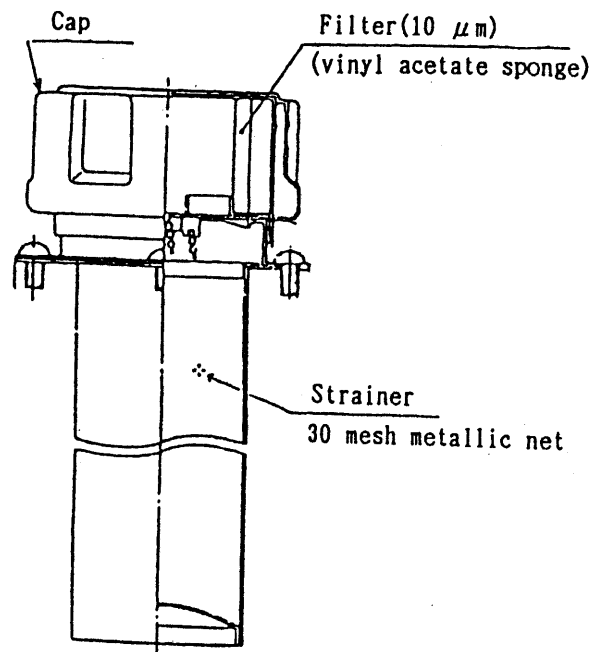

Fig. 18

## Maintenance procedures of the suction strainer

### ① Taking the strainer off

Take the suction strainer off by turning its hex head with a monkey wrench while holding the suction pipe with a pipe wrench.

Note) Do this work is impossible until the tank is removed.

### ② Cleaning

Wipe the strainer with something like waste cloth, and air-blow the net. Wear protective glasses during this work to prevent flying particles from entering into eyes.

### ③ Reattaching

Reattach the strainer in the procedures reverse to ①

Do not iap seal tape around this case.

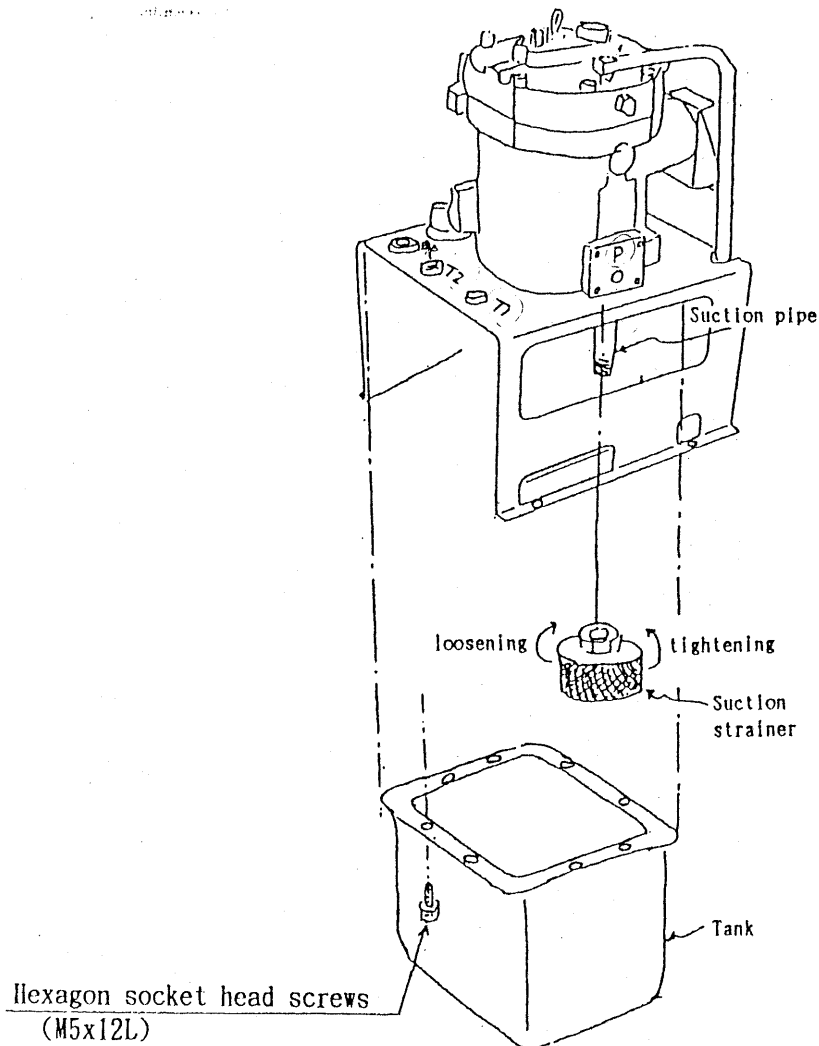
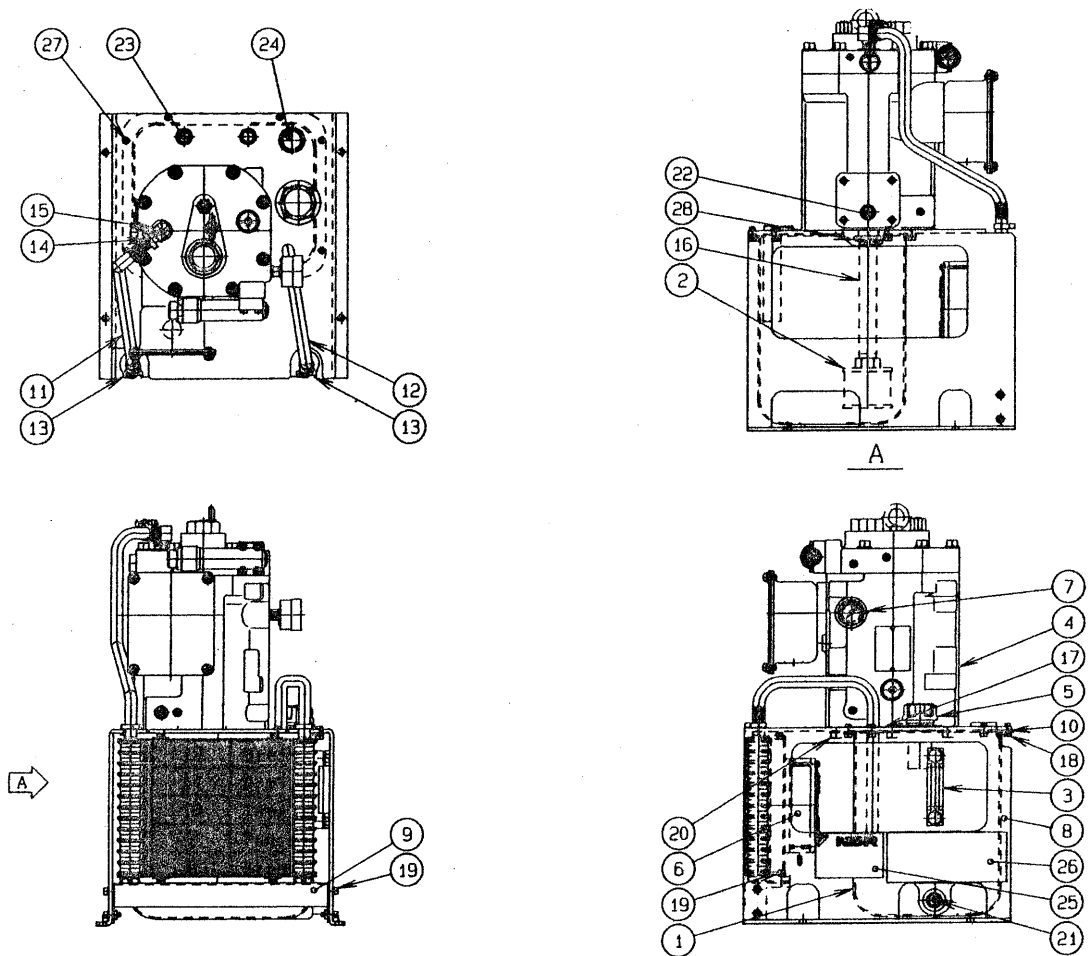

Fig. 19

# 11. Construction cross section and parts list

Caution

Drawing Nos. in the list are for supplement. We cannot submit the drawings.



28	Bushing		1	MTNKB0604	3/4x1/2 inch
27	Thread cap		7	HP30266	
26	Cautions nemeplet		1	1931295	
25	Unit nemeplet		1	1931326	
24	Tapered plug		1	DAZ06	3/4 inch
23	Tapered plug		2	DAZ03	3/8 inch
22	Tapered plug		1	DAZ03	3/8 inch
21	Tapered plug		1	DBP03	3/8 inch
20	Hexagon socket head screws		4	HP30254-15	M8x15
19	Hexagon socket head screws		6	HP30255-16	M5x16
18	Hexagon socket head screws		8	HP30255-12	M5x12
17	Pump gasket	No.500	1	1942709	
16	Suction pipe	SGP	1	1931247-16	SGP1/2W160
15	Drein joint		1	1942667	
14	Snaper		1	HP30304	SNP-8
13	Snaper		2	HP30298	SNP-7-HSO
12	Drein hose	NBR	1	1931291	
11	Drein hose	NBR	1	1931321	
10	Tank packing	NBR	1	1931289	
9	Fan stay	SPHC	1	1931292	
8	Frame	SS400	1	1920764	
7	Pressure gauge		1	Yodogawa Meters	ADGT1/4 φ39x100x10MPa
6	Oil cooler		1	Daikin	DCR10BP-10
5	Oil port, also working as air breather		1	Masuda	MSA-V22
4	Rotor pump		1	Daikin	RP08A1-07-30-001
3	Oil gauge		1	Kyowa	KLA-BOSA
2	Suction strainer		1	Tsukasa Ind.	DHA-04-150
1	Tank (7L)	SPHC	1	1931286	
No.	Part's name	Material symbol	Qty	Drq. No. or maker	Remarks

NDR081-071H-30

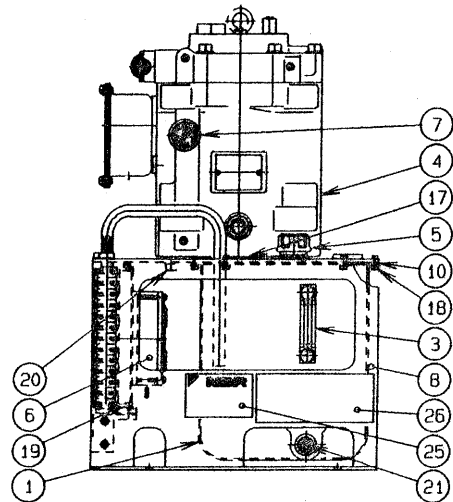
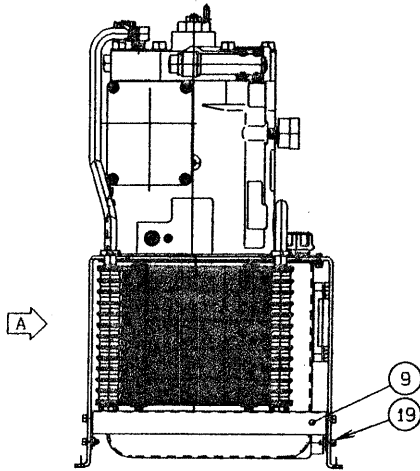
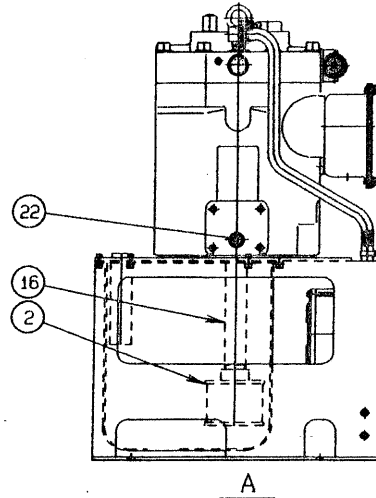
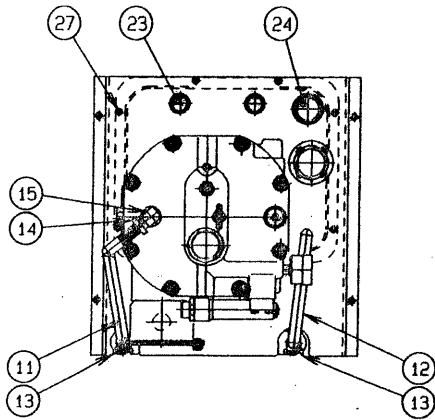

27	Thread cap		6	HP30266	
26	Cautions nemeplet		1	1931295	
25B	Unit nemeplet		1	1931326-2	
25A	Unit nemeplet		1	1931326-1	
24	Tapered plug		1	DAZ08	1 inch
23	Tapered plug		2	DAZ04	1/2 inch
22	Tapered plug		1	DAZ03	3/8 inch
21	Tapered plug		1	DBP03	3/8 inch
20	Hexagon socket head screws		4	HP30254-15	M8x15
19	Hexagon socket head screws		6	HP30255-16	M5x16
18	Hexagon socket head screws		8	HP30255-12	M5x12
17	Pump gasket	No.500	1	1942708	
16	Suction pipe	SGP	1	1931248-17	SGP3/4W170
15	Drein joint		1	1942667	
14	Snaper		1	HP30304	SNP-8
13	Snaper		2	HP30298	SNP-7-HSO
12	Drein hose	NBR	1	1931291	
11	Drein hose	NBR	1	1931322	
10	Tank packing	NBR	1	1931287	
9	Fan stay	SPHC	1	1931293	
8	Frame	SS400	1	1920765	
7	Pressure gauge		1	Yodogawa Meters	ADGT1/4 -#39x100kx10MPa
6	Oil cooler		1	Daikin	DCR10BP-10
5	Oil port, also working as air breather		1	Masuda	MSA-V22
4B	Rotor pump		1	Daikin	RP15A1-22-30-001
4A	Rotor pump		1	Daikin	RP15A1-15-30-001
3	Oil gauge		1	Kyowa	KLA-80SA
2	Suction strainer		1	Tsukasa Ind.	DHA-06-150
1	Tank (10L)	SPHC	1	1931288	
No.	Part's name	Material symbol	Q'ty	Drq. No. or maker	Remarks

NDR151-103H-30 (No. 4B No. 25B)

NDR151-102H-30 (No. 4A No. 25A)



12. Tank oil temperature rise

The figure below shows tank oil temperature rise over the room temperature in the dead head continuous operation.

Tank Oil Temperature Rise Over Room Temperature

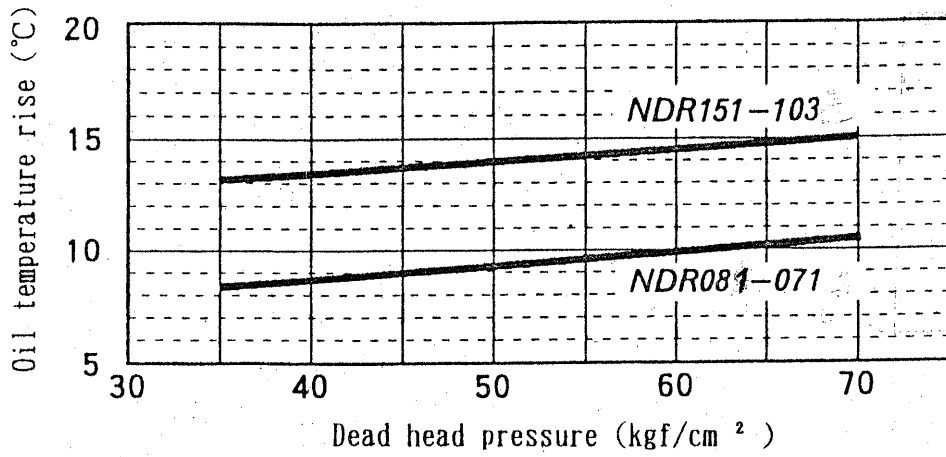



[NDR151-102H-30]  
 [NDR151-103H-30]

Both Models have the identical dimensions.

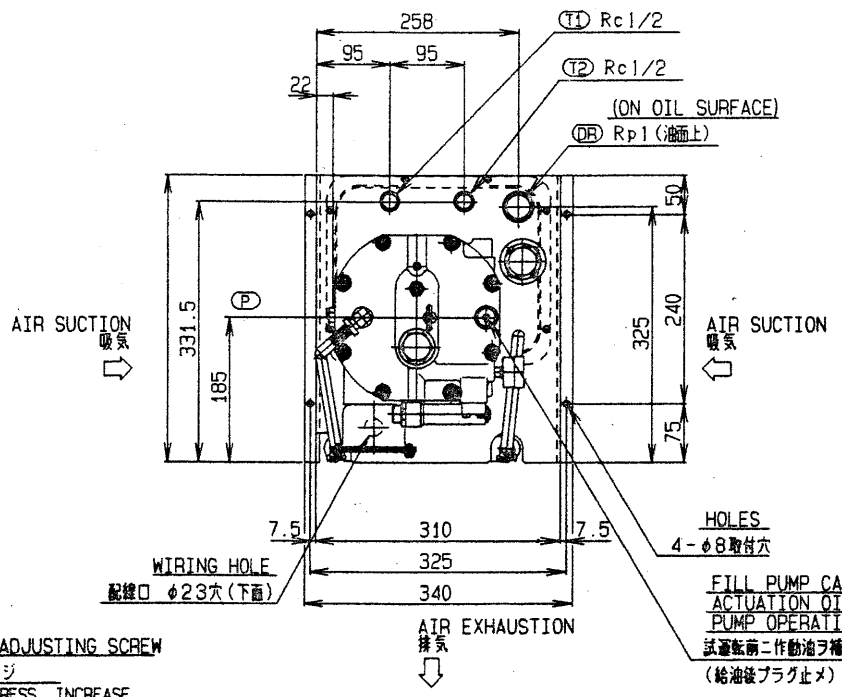
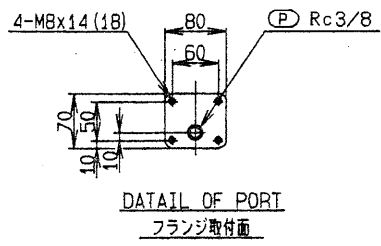

FILL PUMP CASE WITH ACTUATION OIL BEFORE PUMP OPERATION  
 試運転前ニ作動油ヲ補給シテ下サイ  
 (給油後プラグ止め) 2.3L

FLOW ADJUSTING SCREW  
 流量調整ネジ  
 (RIGHT) DISPLACEMENT DECREASE  
 (LEFT) DISPLACEMENT INCREASE  
 (右) CW: 流量減少  
 (左) CCW: 流量増加

PRESS. ADJUSTING SCREW  
 圧力調整ネジ  
 (RIGHT) PRESS. INCREASE  
 (LEFT) PRESS. DECREASE  
 (右) CW: 圧力上昇  
 (左) CCW: 圧力下降

